

仅供参考

REV.	REVISION RECORD	DATE
A0	新图面发行	2017.06.16

### 主要技术参数 Main Specifications

- 线 数 (Poles): 02 to 16
- 接触电阻 (Contact resistance):  $\leq 20m\Omega$
- 绝缘电阻 (Insulation resistance):  $\geq 100M\Omega$
- 额定电压 (Rated voltage): 125 V AC DC
- 额定电流 (Rated current): 1.0A AC DC
- 耐 电 压 (Withstand Voltage): 500V AC/minute
- 温度范围 (Temperature Range):  $-25^{\circ}C \sim +85^{\circ}C$

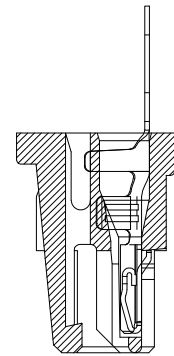
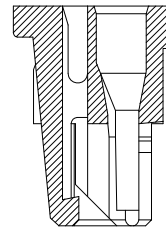
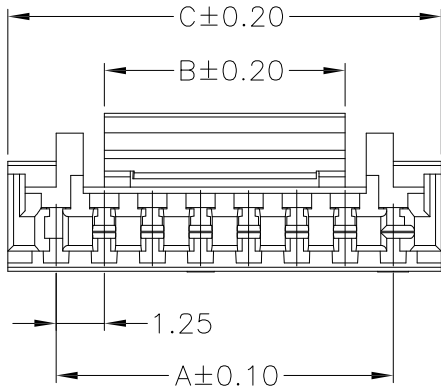
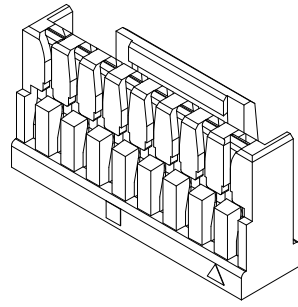

插线状态

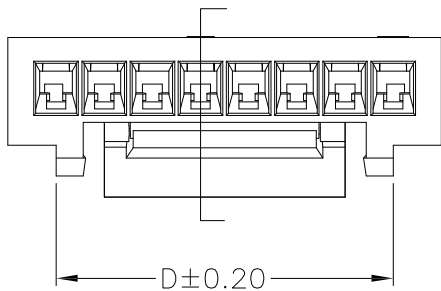
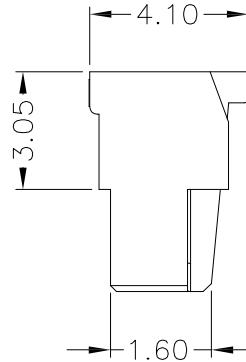
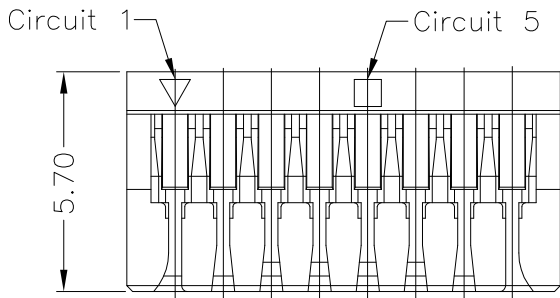

Circuits	Dimensions (mm)			
	DIM. A	DIM. B	DIM. C	DIM. D
02	1.25	2.20	3.75	
03	2.50	2.90	5.00	
04	3.75	4.20	6.25	
05	5.00	4.20	7.50	
06	6.25	6.25	8.75	
07	7.50	6.25	10.00	
08	8.75	6.25	11.25	8.75
09	10.00	6.25	12.50	10.00
10	11.25	8.20	13.75	11.25
11	12.50	8.20	15.00	12.50
12	13.75	8.20	16.25	13.75
13	15.00	8.20	17.50	15.00
14	16.25	8.20	18.75	16.25
15	17.50	8.20	20.00	17.50

A	HOUSING	2~16 PCS	PA66	COLOR:WHITE
ITFM	COMPONENT	Q'TY	MATERIAL	FINISH

	GENERAL TOLERANCES		SCALE: 1:1	NAME	DATE
	LINEAR	ANGLES	APPROVED		
	0.0±0.30	X° REF±6°	DESIGNER		
	UNIT: MM	0.00±0.20	X° ±3°	DRAWN	肖坤权
SIZE: A4	0.000±0.10	X° X'±2°			

深圳市思拓展电子有限公司  
 SHENZHEN SINOTOP ELECTRONICS CO., LTD  
 公司网址: www.szstuo.cn 公司电话: 0755-23765350  
 邮 箱: 2850175982@qq.com 公司传真: 0755-23765341

TITLE: 1.25mmPITCH HOUSING

PART. NO:	ST-WF-125-003Y
DWG. NO:	
REV:	A0
SHEET:	1/1

仅供参考

REV.	REVISION RECORD	DATE
A0	新图面发行	2017.06.16

Specifications:

Contact resistance:  $\leq 20m\Omega$   
 Insulation resistance:  $\geq 100M\Omega$   
 Rated voltage: 125V AC DC  
 Rated current: 1.0A AC DC  
 Withstand Voltage: 500V AC/minute  
 Temperature Range:  $-25^{\circ}C \sim +85^{\circ}C$

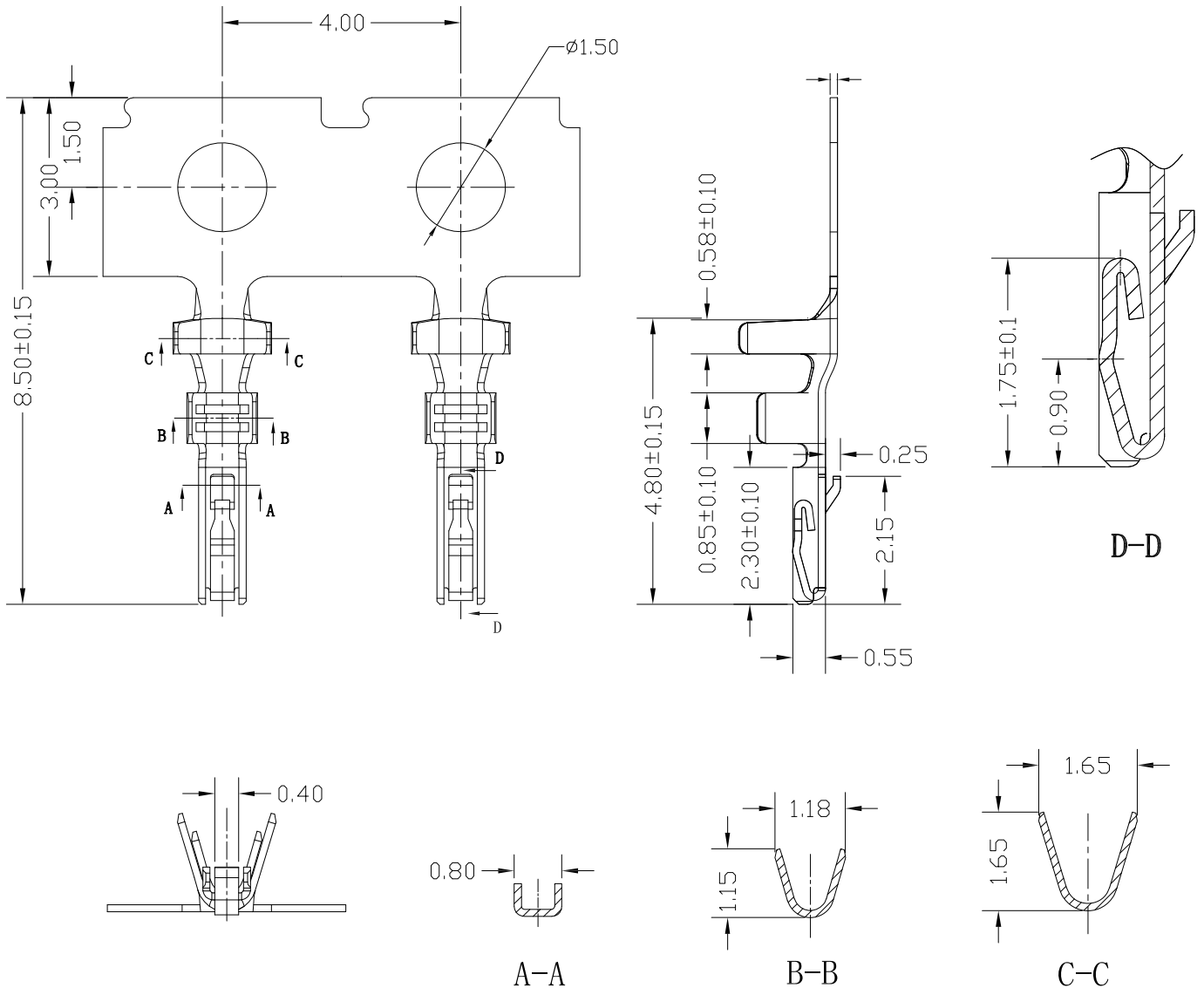

Wire Range	Insulation O. D.	Material	Finish	Qty/Reel
AWG #26~#30	1.00mm (max)	Phosphor bronze	Tin-plated	/

	GENERAL TOLERANCES		SCALE: 1:1	NAME	DATE	深圳市思拓展电子有限公司 SHENZHEN SINOTOP ELECTRONICS CO., LTD 公司网址: www.szstuo.cn 公司电话: 0755-23765350 邮箱: 2850175982@qq.com 公司传真: 0755-23765341	PART. NO:	
	LINEAR	ANGLES	APPROVED				ST-WF-125-003T	
	0.0±0.30	X° REF±6°	DESIGNER				DWG. NO:	
	UNIT: MM	0.00±0.20	X° ±3°	DRAWN	肖坤权		2017.06.16	REV: A0 SHEET: 1/1
SIZE: A4	0.000±0.10	X° X'±2°	TITLE: 1.25mm PITCH TERMINAL					