

仅供参考

REV.	REVISION RECORD	DATE
A0	新图面发行	2017. 06. 16

Specifications:
 Voltage Rating : 250V AC/DC
 Current Rating : 8A AC,DC
 Withstand Voltage : 1500V AC/minute
 Contact Resistance : 40mΩ(MAX.)
 Insulation Resistance : 1000MΩ(MIN.)
 Temperature Range : -40°C~+105°C

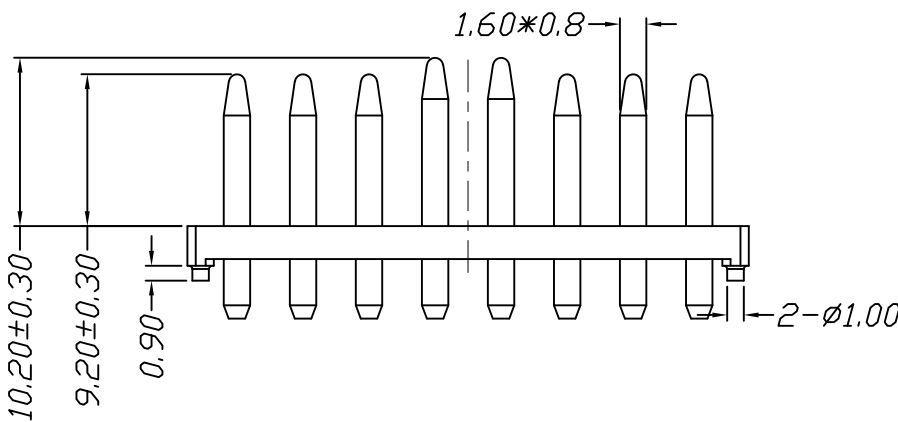
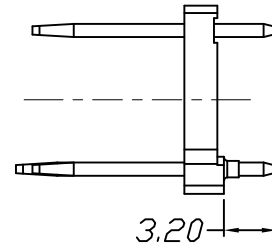
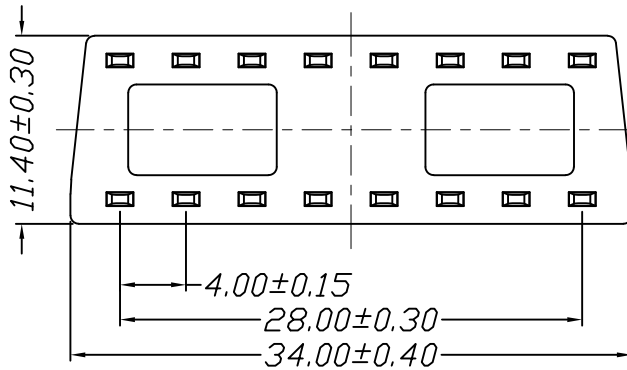
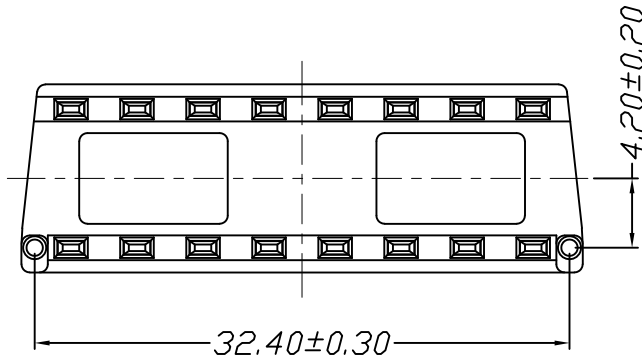
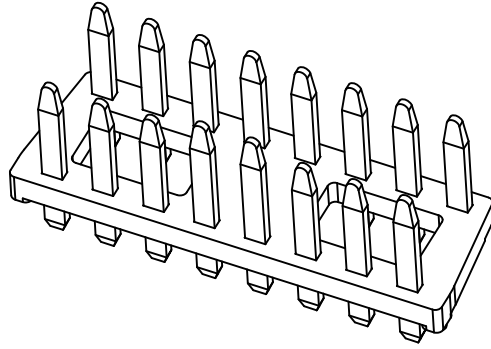

Material	Color	PIN Material
Nylon	Black	Brass/Tin-plated

	GENERAL TOLERANCES		SCALE: 1:1	NAME	DATE	深圳市思拓展电子有限公司 SHENZHEN SINOTOP ELECTRONICS CO., LTD 公司网址: www.szstuo.cn 公司电话: 0755-23765350 邮箱: 2850175982@qq.com 公司传真: 0755-23765341	PART NO: STP44001W00-2X8PA-A1-XX
	LINEAR	ANGLES	APPROVED				DWG. NO:
UNIT: MM	0.00±0.25	X° REF±6°	DESIGNER			TITLE: 4.00m Pitch 180° Dual Wafer DIP Type	REV: A0
SIZE: A4	0.000±0.15	X° X'±2°	DRAWN	肖坤权	2017. 06. 16		SHEET: 1/1

仅供参考

REV.	REVISION RECORD	DATE
A0	新图面发行	2017.06.16

Specifications:
 Voltage Rating : 250V AC/DC
 Current Rating : 8A AC,DC
 Withstand Voltage : 1500V AC/minute
 Contact Resistance : 40mΩ(MAX.)
 Insulation Resistance : 1000MΩ(MIN.)
 Temperature Range : -40°C~+105°C

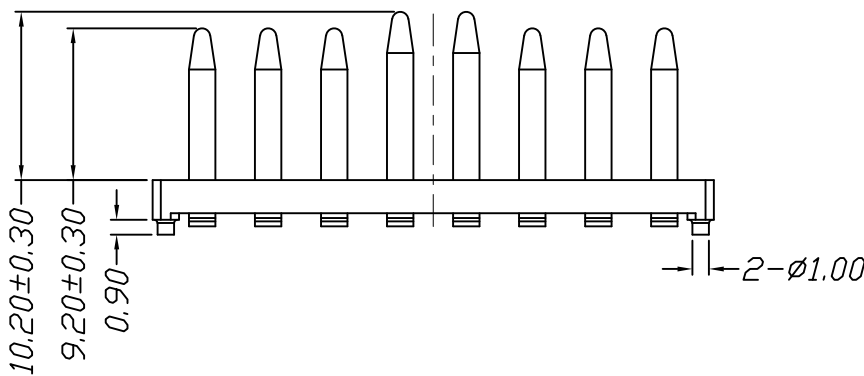
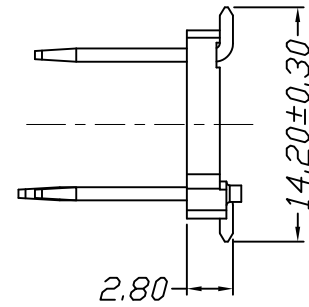
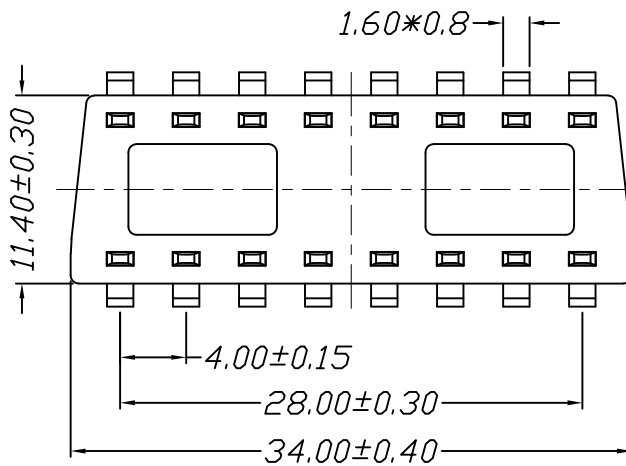
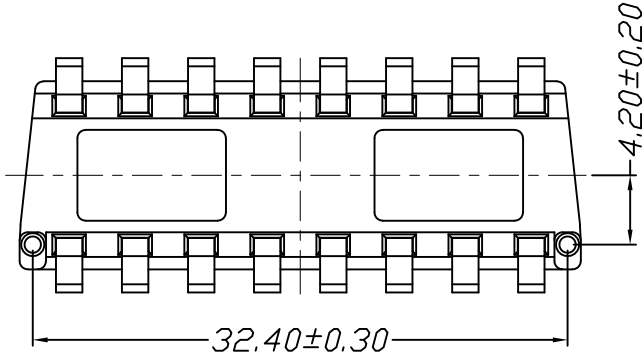
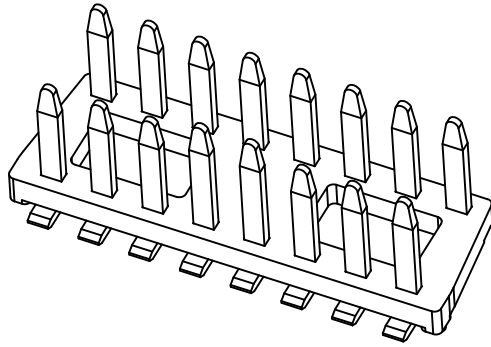

Material	Color	PIN Material
Nylon	Black	Brass/Tin-plated

	GENERAL TOLERANCES		SCALE: 1:1	NAME	DATE
	LINEAR	ANGLES			
	0.0±0.35	X° REF±6°	APPROVED		
UNIT: MM	0.00±0.25	X° ±3°	DESIGNER		
SIZE: A4	0.000±0.15	X° X'±2°	DRAWN	肖坤权	2017.06.16

深圳市思拓展电子有限公司
 SHENZHEN SINOTOP ELECTRONICS CO., LTD
 公司网址: www.szsituo.cn 公司电话: 0755-23765350
 邮 箱: 2850175982@qq.com 公司传真: 0755-23765341

TITLE:
4.00mm Pitch 180° Dual Wafer SMT Type

PART NO:	STP44001W00-2X8PA-A2-XX	
DWG NO:		
REV:	A0	SHEET: 1/1