

仅供参考

REV.	REVISION RECORD	DATE
A0	新图面发行	2017.06.16

Specifications:
 Voltage Rating : 250V AC/DC
 Current Rating : 8A AC,DC
 Withstand Voltage : 1500V AC/minute
 Contact Resistance : 40mΩ(MAX.)
 Insulation Resistance : 1000MΩ(MIN.)
 Temperature Range : -55°C~+105°C

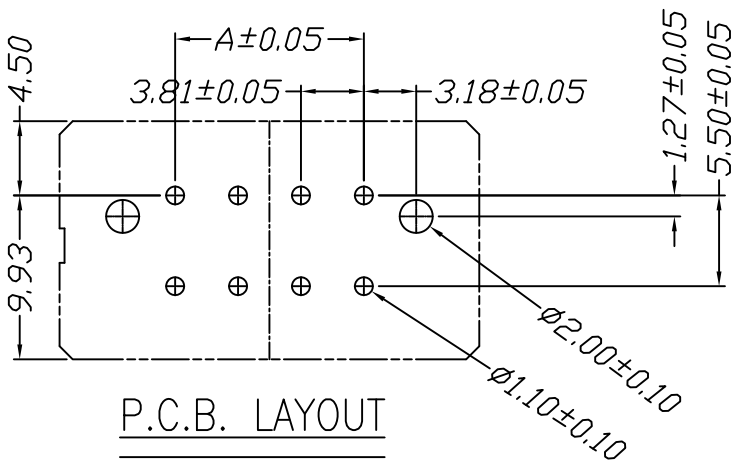
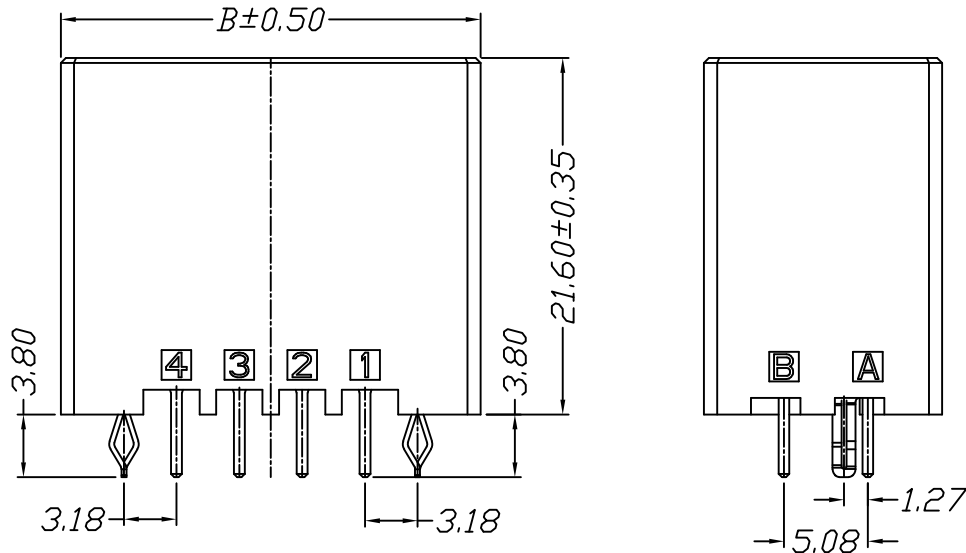
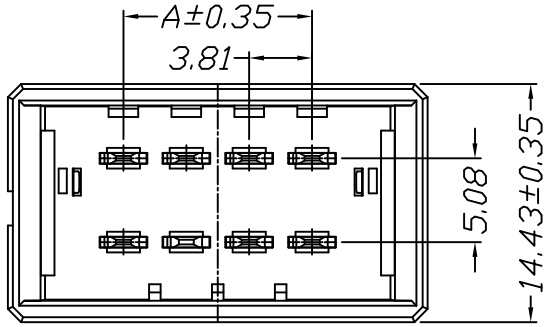
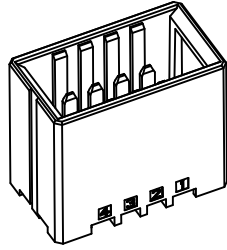

Poles	Dimensions	
	A	B
2*3P	7.62	21.62
2*4P	11.43	25.43
2*5P	15.24	29.24
2*6P	19.05	33.05
2*8P	26.67	37.67
2*10P	34.29	48.29

Material	Color	PIN Material
PBT	Black	Brass/Tin-plated

	GENERAL TOLERANCES		SCALE:	NAME	DATE
	LINEAR	ANGLES	1:1		
0.0±0.35	X° REF±6°	APPROVED			
UNIT: MM	0.00±0.25	X° ±3°	DESIGNER		
SIZE: A4	0.000±0.15	X° X'±2°	DRAWN	肖坤权	2017.06.16

深圳市思拓展电子有限公司
 SHENZHEN SINOTOP ELECTRONICS CO., LTD
 公司网址: www.szsituo.cn 公司电话: 0755-23765350
 电子邮箱: 2850175982@qq.com 公司传真: 0755-23765341

TITLE:
3.81mm Pitch 180° Dual Wafer DIP Type

PART. NO:	STP43811W00-2XNPA-A1-XX	
DWG. NO:		
REV:	A0	SHEET: 1/1

仅供参考

REV.	REVISION RECORD	DATE
A0	新图面发行	2017.06.16

Specifications:
 Voltage Rating : 250V AC/DC
 Current Rating : 8A AC,DC
 Withstand Voltage : 1500V AC/minute
 Contact Resistance : 40mΩ(MAX.)
 Insulation Resistance : 1000MΩ(MIN.)
 Temperature Range : -55°C~+105°C

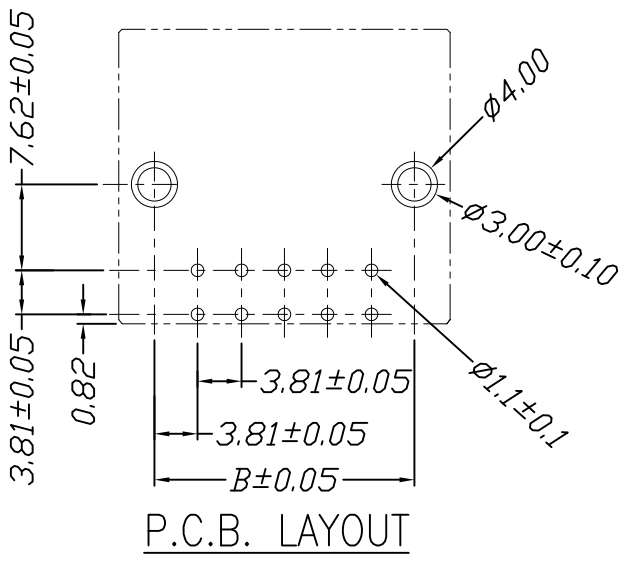
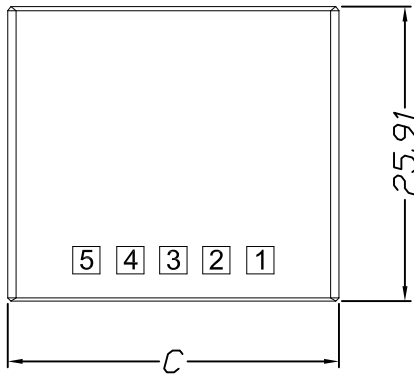
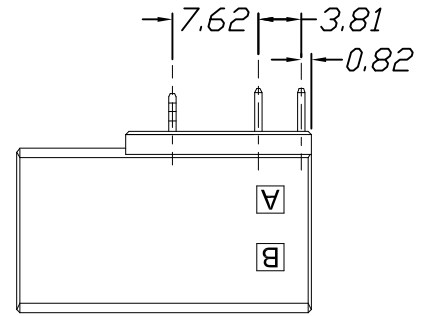
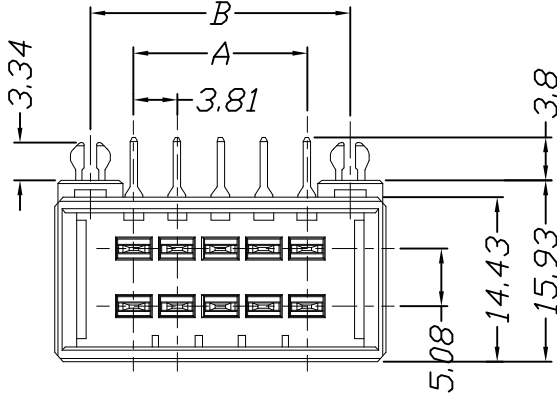
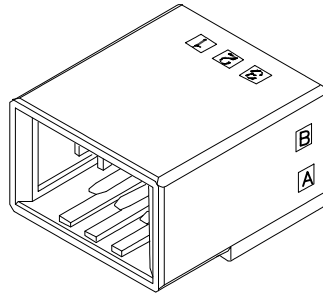

Poles	Dimensions		
	A	B	C
2*3P	7.62	15.24	21.62
2*4P	11.43	19.05	25.43
2*5P	15.24	22.86	29.24
2*6P	19.05	26.67	33.05
2*8P	26.67	34.29	40.67
2*10P	34.29	41.91	48.29

Material	Color	PIN Material
PBT	Black	Brass/Tin-plated

	GENERAL TOLERANCES		SCALE:	NAME	DATE
	LINEAR	ANGLES	1:1		
	0.0±0.35	X° REF±6°	APPROVED		
UNIT: MM	0.00±0.25	X° ±3°	DESIGNER		
SIZE: A4	0.000±0.15	X° X'±2°	DRAWN	肖坤权	2017.06.16

深圳市思拓展电子有限公司
 SHENZHEN SINOTOP ELECTRONICS CO., LTD
 公司地址: WWW.SZSITUAO.CN 公司电话: 0755-23765350
 邮编: 2850175982@qq.com 公司传真: 0755-23765341

PART NO:	STP43811W90-2XNPA-A1-XX	
DWG NO:		
REV:	A0	SHEET: 1/1

TITLE:
3.81mm Pitch 90° Dual Wafer DIP Type

仅供参考

REV.	REVISION RECORD	DATE
A0	新图面发行	2017.06.16

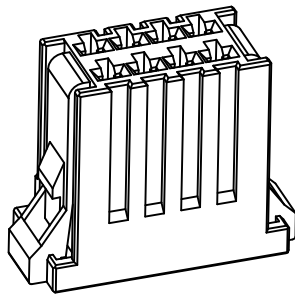

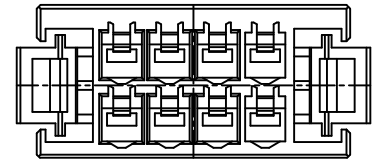
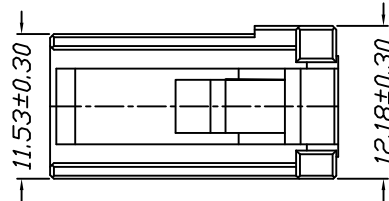
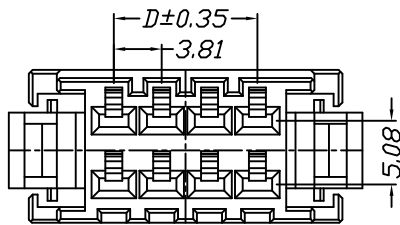
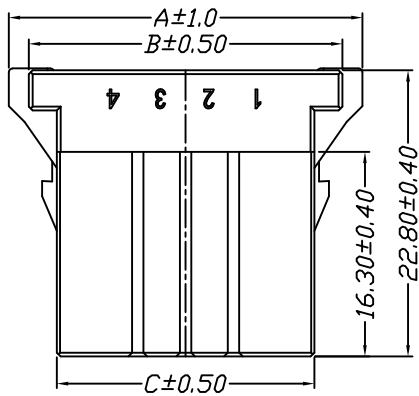

Specifications:
 Voltage Rating : 250V AC/DC
 Current Rating : 8A AC,DC
 Withstand Voltage : 1500V AC/minute
 Contact Resistance : 40mΩ(MAX.)
 Insulation Resistance : 1000MΩ(MIN.)
 Temperature Range : -55°C~+105°C



Poles	Dimensions			
	A	B	C	D
2*3P	24.36	21.16	16.70	7.62
2*4P	28.17	24.97	20.51	11.43
2*5P	31.98	28.78	24.32	15.24
2*6P	35.79	32.59	28.13	19.05
2*8P	43.41	40.21	35.75	26.67
2*10P	51.03	47.83	43.37	34.29

Material	Color
PBT UL94V-0	BLACK

	GENERAL TOLERANCES		SCALE: 1:1	NAME	DATE	 深圳市思拓展电子有限公司 SHENZHEN SINOTOP ELECTRONICS CO., LTD 公司网址: www.szstuo.cn 公司电话: 0755-23765350 邮箱: 2850175982@qq.com 公司传真: 0755-23765341	PART. NO: STP43811H00-2XNPA-PT
	LINEAR	ANGLES					
UNIT: MM	0.00±0.25	X° ±3°	DESIGNER			TITLE:	DWG. NO:
SIZE: A4	0.000±0.15	X° X' ±2°	DRAWN	肖坤权	2017.06.16	3.81mm PITCH Housing	REV: A0 SHEET: 1/1

仅供参考

REV.	REVISION RECORD	DATE
A0	新图面发行	2017.06.16

Specifications:
 Voltage Rating : 250V AC/DC
 Current Rating : 8A AC,DC
 Withstand Voltage : 1500V AC/minute
 Contact Resistance : 40mΩ(MAX.)
 Insulation Resistance : 1000MΩ(MIN.)
 Temperature Range : -55°C~+105°C

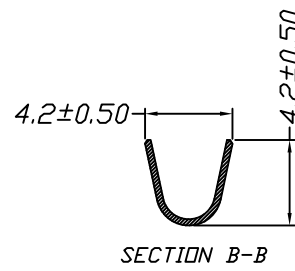
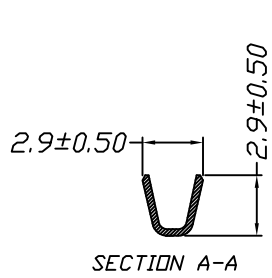
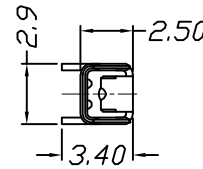
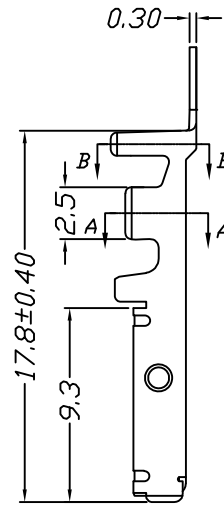
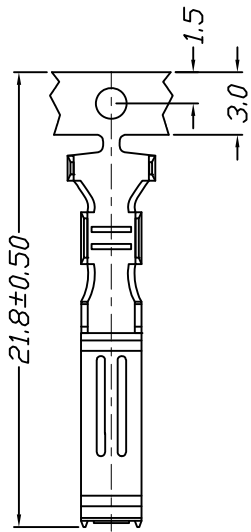

Wire Range	Insulation O.D.	Material	Finish	Qty/Reel
AWG #16~#20	1.25mm Max	Phosphor bronze	Au or Sn	

	GENERAL TOLERANCES		SCALE: 1:1	NAME	DATE	深圳市思拓展电子有限公司 SHENZHEN SINOTOP ELECTRONICS CO., LTD 公司网址: www.szstuo.cn 公司电话: 0755-23765350 邮箱: 2850175982@qq.com 公司传真: 0755-23765341	PART. NO: STP43811T0P-XX
	LINEAR	ANGLES	APPROVED				DWG. NO:
UNIT: MM	0.0±0.35	X° REF±6°	DESIGNER			TITLE: 3.81mm PITCH Crimp Terminal	REV: A0
SIZE: A4	0.000±0.15	X° X'±2°	DRAWN	肖坤权	2017.06.16		SHEET: 1/1

仅供参考

REV.	REVISION RECORD	DATE
A0	新图面发行	2017.06.16

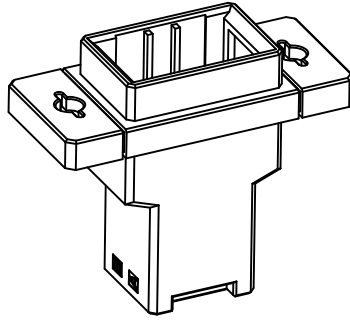

Specifications:
 Voltage Rating : 250V AC/DC
 Current Rating : 8A AC,DC
 Withstand Voltage : 1500V AC/minute
 Contact Resistance : 40mΩ(MAX.)
 Insulation Resistance : 1000MΩ(MIN.)
 Temperature Range : -55°C~+105°C

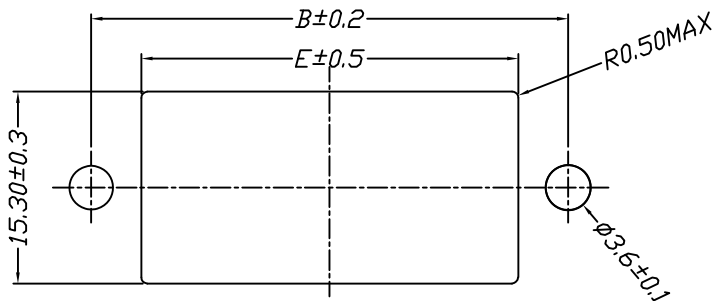
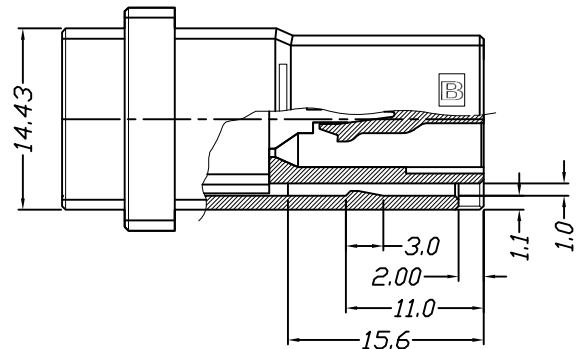
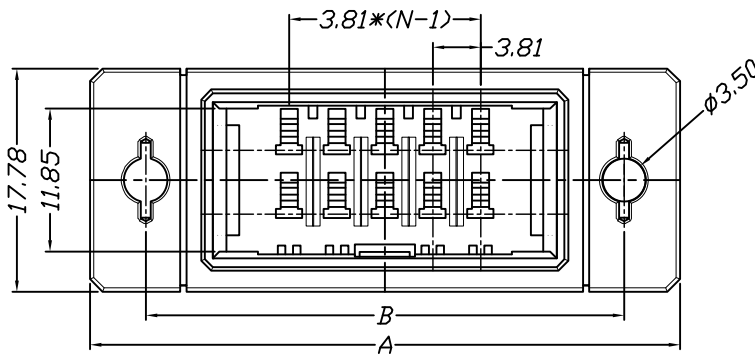
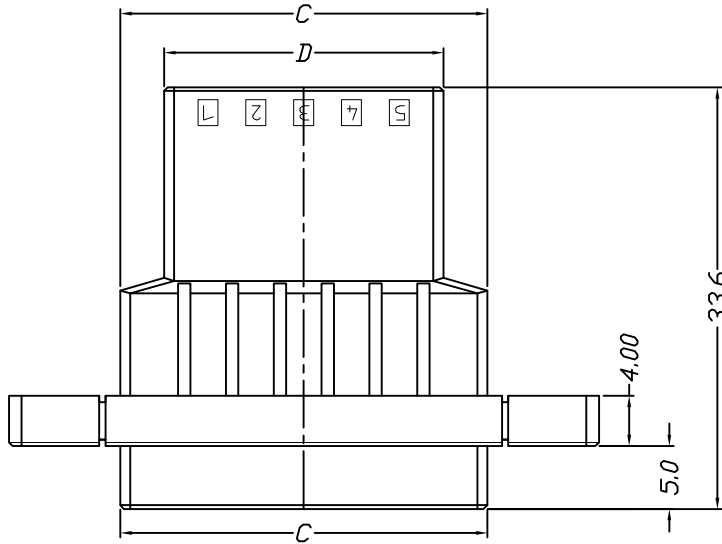

RECOMMENDED PANEL LAYOUT

Poles	Dimensions				
	A	B	C	D	E
2*10P	67.0	58.0	48.29	41.29	49.2
2*8P	59.0	50.0	40.67	33.67	41.6
2*6P	51.0	42.0	33.05	26.05	34.0
2*5P	47.0	38.0	29.24	22.24	30.2
2*3P	40.0	31.0	21.62	14.62	22.6

Material	Color
PBT UL94V-0	BLACK

	GENERAL TOLERANCES		SCALE: 1:1	NAME	DATE	深圳市思拓展电子有限公司 SHENZHEN SINOTOP ELECTRONICS CO., LTD 公司地址: WWW.SZSITUAO.CN 公司电话: 0755-23765350 邮编: 2850175982@qq.com 公司传真: 0755-23765341	PART. NO: STP43811H00-2XNPA-2-PT
	LINEAR	ANGLES					
UNIT: MM	0.00±0.25	X° REF±6°	DESIGNER			TITLE:	DWG. NO:
SIZE: A4	0.000±0.15	X° X'±2°	DRAWN	肖坤权	2017.06.16	3.81mm PITCH Housing	REV: A0 SHEET: 1/1

仅供参考

REV.	REVISION RECORD	DATE
A0	新图面发行	2017.06.16

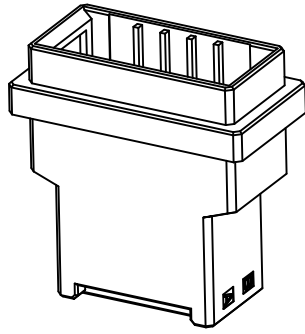

Specifications:
 Voltage Rating : 250V AC/DC
 Current Rating : 8A AC,DC
 Withstand Voltage : 1500V AC/minute
 Contact Resistance : 40mΩ(MAX.)
 Insulation Resistance : 1000MΩ(MIN.)
 Temperature Range : -55°C~+105°C

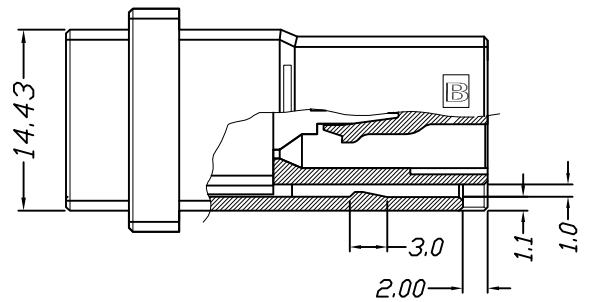
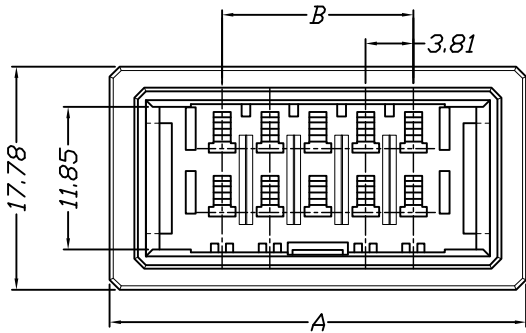
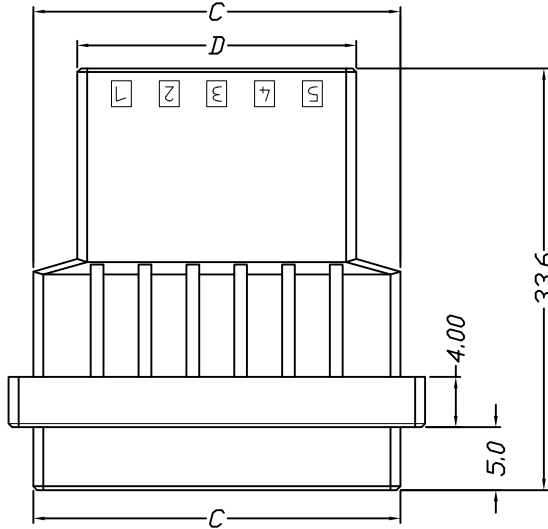

Poles	Dimensions			
	A	B	C	D
2*10P	52.24	34.29	48.29	41.29
2*8P	44.62	26.67	40.67	33.67
2*6P	37.00	19.05	33.05	26.05
2*5P	33.19	15.24	29.24	22.24
2*4P	29.38	11.43	25.43	18.43
2*3P	25.57	7.62	21.62	14.62

Material	Color
PBT UL94V-0	BLACK

	GENERAL TOLERANCES		SCALE: 1:1	NAME	DATE	深圳市思拓展电子有限公司 SHENZHEN SINOTOP ELECTRONICS CO., LTD 公司地址: WWW.SZSITUAO.CN 公司电话: 0755-23765350 邮编: 2850175982@qq.com 公司传真: 0755-23765341	PART. NO: STP43811H00-2XNPA-3-PT
	LINEAR	ANGLES	APPROVED				DWG. NO:
UNIT: MM	0.0±0.35	X° REF±6°	DESIGNER			TITLE: 3.81mm PITCH Housing	REV: A0 SHEET: 1/1
SIZE: A4	0.000±0.15	X° X'±2°	DRAWN	肖坤权	2017.06.16		

仅供参考

REV.	REVISION RECORD	DATE
A0	新图面发行	2017.06.16

Specifications:
 Voltage Rating : 250V AC/DC
 Current Rating : 8A AC,DC
 Withstand Voltage : 1500V AC/minute
 Contact Resistance : 40mΩ(MAX.)
 Insulation Resistance : 1000MΩ(MIN.)
 Temperature Range : -55°C~+105°C

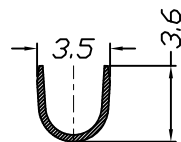
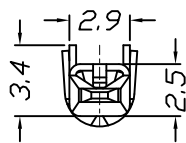
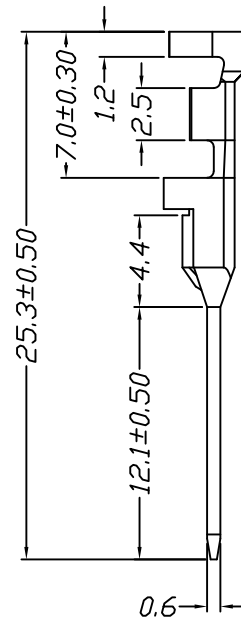
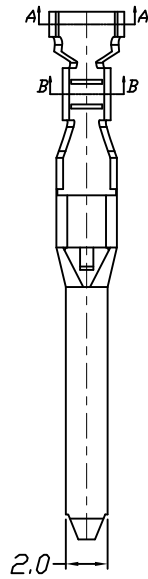

SECTION A-A

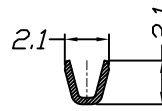

SECTION B-B

Wire Range	Insulation O.D.	Material	Finish	Qty/Reel
AWG #20~#24	1.20mm Max	Phosphor bronze	Au or Sn	

	GENERAL TOLERANCES		SCALE: 1:1	NAME	DATE	深圳市思拓展电子有限公司 SHENZHEN SINOTOP ELECTRONICS CO., LTD 公司网址: www.szstuo.cn 公司电话: 0755-23765350 邮箱: 2850175982@qq.com 公司传真: 0755-23765341	PART. NO: STP33811T0P-XX-T
	LINEAR	ANGLES	APPROVED				DWG. NO:
UNIT: MM	0.0±0.35	X° REF±6°	DESIGNER			TITLE: 3.81mm PITCH Crimp Terminal	REV: A0 SHEET: 1/1
SIZE: A4	0.00±0.15	X° X'±2°	DRAWN	肖坤权	2017.06.16		